

# Portable Injection Unit

# IU5A

## 「Portable Injection Unit」

It is a portable add-on injection unit that permits a general-purpose injection molding machine to use multi-color molding molds, such as core back, core rotation, and hot runner types. It can be removed from the machine when it is not needed.

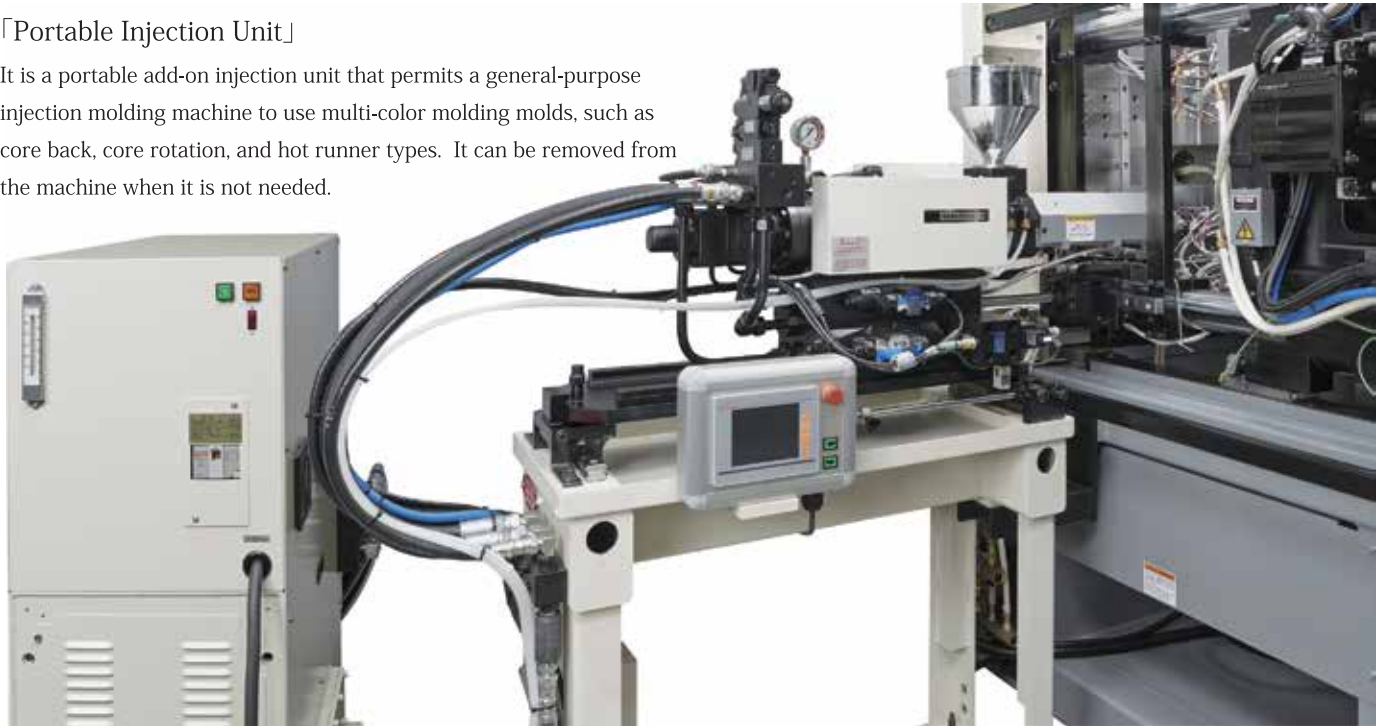

## IU5A

Specifications		Unit	IU5A	
Injection	Screw diameter	inchi (mm)	0.87 (22)	1.02 (26)
	Injection capacity	inch <sup>3</sup> (cm <sup>3</sup> ) (oz)	2.1 (35) (1.2)	3.0 (49) (1.6)
	Plasticization capacity (PS)	lbs/h (kg/h)	33.1 (15)	48.5 (22)
	Injection pressure	psi (Mpa) (kgf/cm <sup>2</sup> )	37146 (256) (2612)	29456 (203) (2071)
	Injection rate	inch <sup>3</sup> /s (cm <sup>3</sup> /s)	3.1 (50)	4.3 (71)
	Injection velocity	inch/s (mm/s)	5.2 (133)	5.2 (133)
	Screw stroke	inch/s (mm/s)	3.6 (92)	3.6 (92)
	Screw speeds	rpm	0 ~ 330	0~330
	Injection force	US ton (kN) (tf)	10.9 (97) (9.9)	12.1 (108) (11.0)
	Nozzle touch force	US ton (kN) (tf)	1.8 (16) (1.6)	1.8 (16) (1.6)
	Hopper capacity (optional)	Gal (L)	34.0 (15)	34.0 (15)
Others	Heater band capacity	kW	3.77	4.22
	Machine dimensions (L×W×H)	inch (m)	Injection unit : 71.3×31.5×68.5(1.81×0.8×1.74) Hydraulic unit : 24.8×31.5×48.8(0.63×0.8×1.24)	
	Machine weight	lbs (t)	Injection unit : 1102 (0.5) Hydraulic unit : 882(0.4)	

- Actual plasticizing capacity may vary, depending on the molding conditions and materials used.
- The specifications are subject to change without notice due to performance upgrades.
- 1MPa=10.2kgf/cm<sup>2</sup>≒10kgf/cm<sup>2</sup>, 1kN=0.102tf≒0.1tf

Injection unit

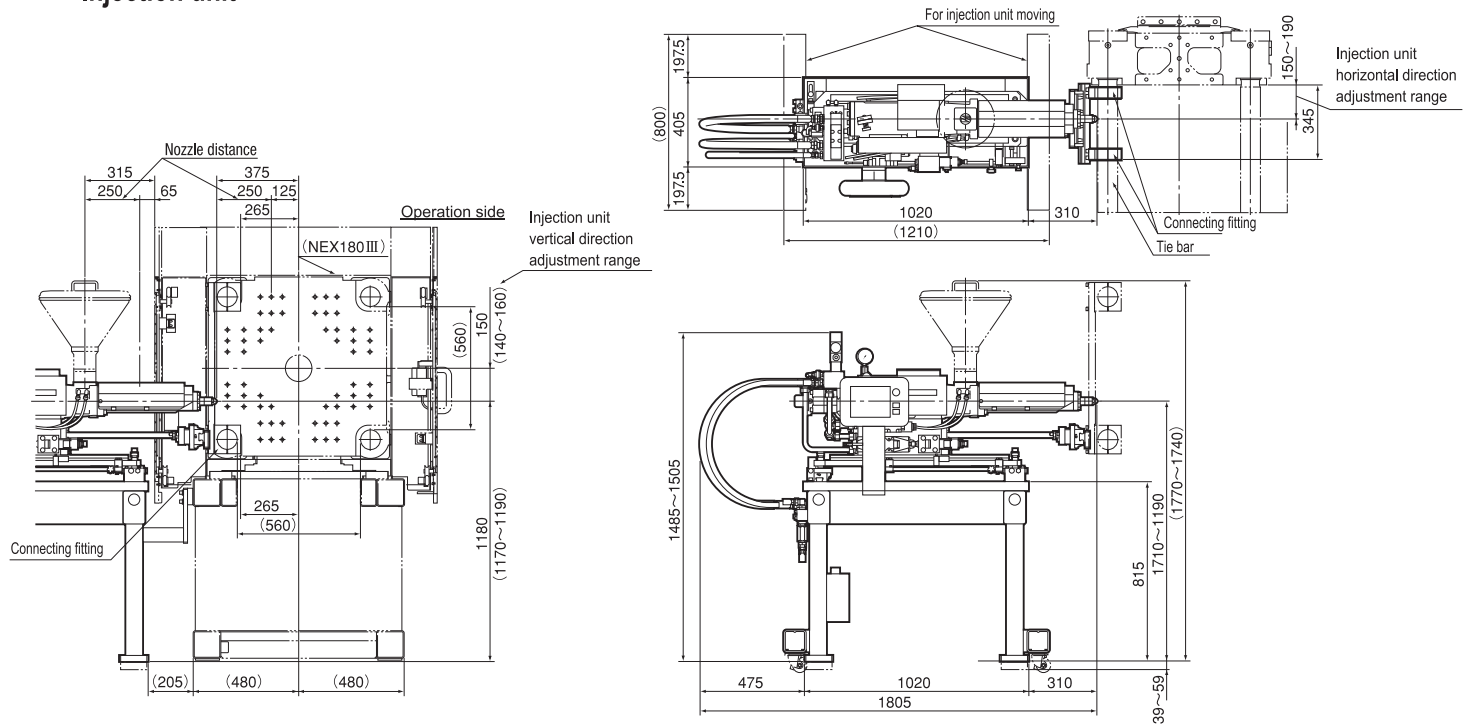

Hydraulic unit

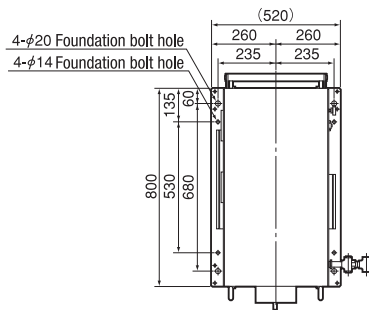

Installation foundation diagram

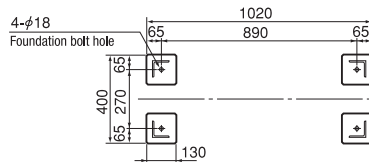

Hopper fixation diagram

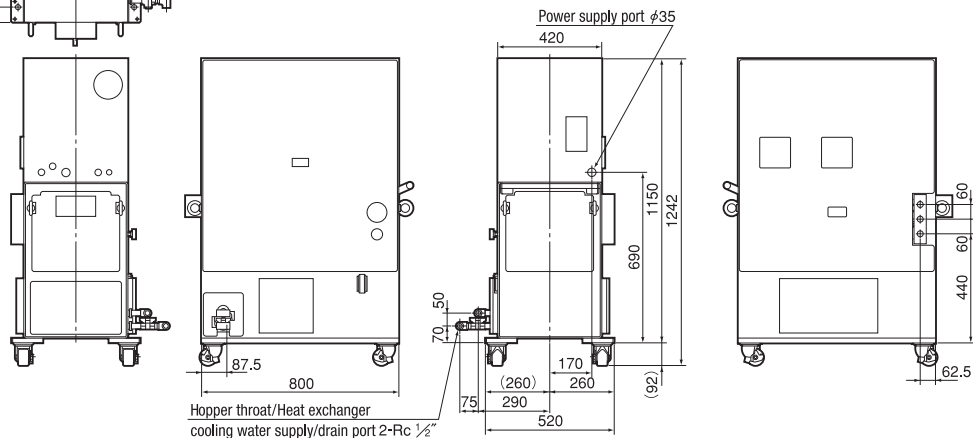
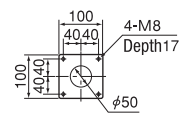

Unit : metric(mm)

NISSEI AMERICA, INC.

LOS ANGELES, CALIFORNIA

CORPORATE HEADQUARTERS

1480 North Hancock Street, Anaheim, CA 92807

TEL: (714)693-3000 FAX: (714)693-7777

http://www.nisseiamerica.com

CHICAGO, ILLINOIS TEL: (847)228-5000

JAMESBURG, NEW JERSEY TEL: (732)271-4885

ATLANTA, GEORGIA TEL: (770)421-0700

AUBURN, MASSACHUSETTS TEL: (508)754-5600

TAMPA, FLORIDA TEL: (727)773-8773



NISSEI PLASTIC INDUSTRIAL CO., LTD.

http://www.nisseijushi.co.jp

Specifications, dimensions, designs, and other contents of this flyer are subject to change without notice due to continuous performance improvement.