

# Quality & Production Management System PQ Manager ver.3



By networking the molding machines with PQ Manager permits real-time collection of quality and production data of the injection molding machines.

### New function

- Installation of a viewing application no longer needed: browser-based application (connection of other brand's machines also possible).
- Viewing from a tablet PC possible
- The maximum number of the machines can be connected to the system: expanded from 50 to 100
- Monitor data display expanded from eight electable categories to all categories  
Number of units that can collect waveform simultaneously: expanded from one machine to multiple units
- It is supported in three languages: Japanese, English, Chinese and Korean.

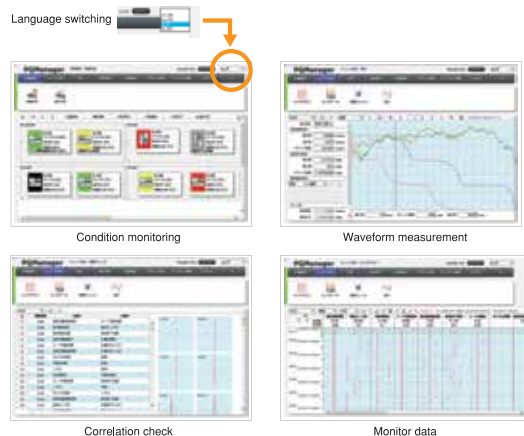

### Group control system

#### Group control system for a variety of models

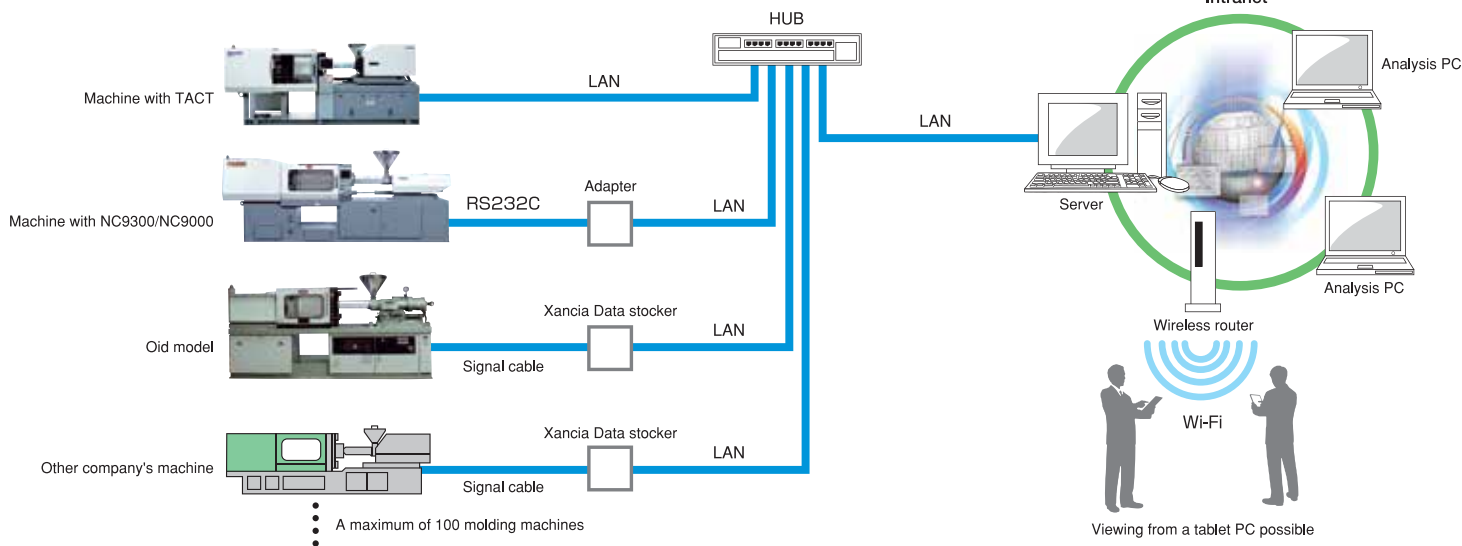

### Function Matrix

	Function	Machine with TACT	Machine with NC9300 · NC9000	Machine with NC-8000 · NC8300 · NC8500, NC21 and other brand
	Machine modification	Molding machine program change required	Installation of an adapter and molding machine program change required	Installation of an Xancia DST
	Connection with molding machine	LAN	LAN	LAN
Production management	Status monitoring	○	○	○
	Operation history management	○	○	○ (*1)
	Actual production	○	○	○
	Mold history management	○	○	○
Quality management	Monitor data collection/analysis	○	○	×
	Wave profile collection/analysis	○	×	×
	Molding condition management	○	○	×

\*1 Status history only